



# FMR V-SERIES SPRAYER 2 ROW GEN II



# FMR V-SERIES SPRAYER 2 ROW GEN II

The Generation II V-Series Vineyard Sprayer takes a great concept and makes it even better! Building on the base of the original V-Series vine sprayer released in 2008, the Generation II machine introduces a number of innovations and developments, bringing additional benefits to owners and operators.

Features include:

- Tank design provides improved weight distribution for stability
- Boom system offers improved functionality and flexibility including hydraulic row width adjustment
- Tangential fan standardised at 1.8mt length for improved delivery in all canopies
- 'Wet boom' system with 8 roll-over nozzle bodies
- Pumps and valves slide or fold out, making regular servicing simple and easy
- Overall manoeuvrability and stability improved with overall height reduced and centre of mass lowered
- Improved tank level indicator located on rear frame
- Optimised hydraulic system for greater efficiency and function
- Auto rate controller for improved operator comfort and control

## FEATURES:

- Composite tank - 2300L, 3000L, 4000L options
- 200lt fresh water for flushing & hand wash
- Hot dip galvanised chassis & boom
- Genuine Weber tangential fans with 8 nozzle wet boom
- Automatic rate controller with hydraulic control for booms
- 100% hydraulic drive - just 57lt/min required
- Storage box option available
- Independent boom adjustment option for terraced vineyards

## BENEFITS:

- Targeted delivery results in less off-target drift
- Tangential fan delivers a turbulent stream of high volume, low pressure air across a full length curtain, creating leaf movement and contributing to inner canopy penetration and even deposition to all target surfaces
- Improved operator safety and experience
- Longevity and reliability from strong, robust design
- Ease of cleaning and maintenance
- Fast connect and disconnect from tractor
- Developed, tested and proven in New Zealand & Australian vineyards

## Additional options available at ordering:

- Terrace configuration: hydraulic height adjustable booms with individual L/R (only available on 2-row with tandem axle)
- 3-point pivoting hitch
- New heavy duty walking beam axle system
- Hydraulic brakes

## MODEL DIMENSIONS:

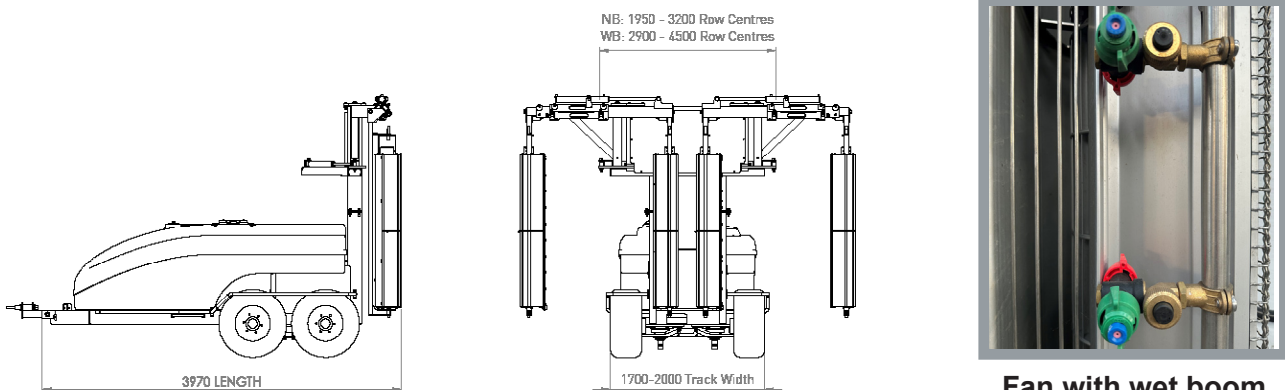

Fan with wet boom

TRS Wholesale Limited

52 Rene Street, Springlands, Blenheim 7201, New Zealand  
Postal Address : PO Box 162, Blenheim 7240, New Zealand

Telephone : +64 3 572 5150 | Freephone: 0800 367 583

Email: sales@trswholesale.co.nz | FMR.NZ

Your local dealer: